

# bosal

**Инструкция  
по монтажу тягово-цепного  
устройства шарового типа 6501 А  
для автомобилей  
УАЗ-469; -31512;  
-3303;-2206; -3962**

	1972 -...
	1000
	75
	7,9



462800,

« - »

18

т. : (35363) 7-05-06

факс : (35363) 7-13-20

т. : (495) 785-66-07

www.bosal-autoflex.ru

« - »;	" (8182) 22-48-15
"	" 8(8442) 98-74-98
"	" 8(343) 379-39-89, 373-42-73
"	" 8(343) 26-88-308
"	" 8(3952) 710-194
"	" 8(495) 777-54-59
"	" 8(495)745-79-11
"	" 8(495) 788-95-97
"	" 8(495) 720-51-03
"	" 8(3532) 57-99-85
"	" 8-905-899-5012
"	" 8(383) 291-59-60
"	" 8(831) 279-53-24
"	" 8(3422) 98-27-20
"	" 8(342) 220-87-87
"	" 8-927-002-90-06
"	" 8(3462) 24-00-44
"	" 8(3842) 21-14-76
"	" 8-902-940-4151
"	" 8(3452) 32-22-12, 41-52-62
"	" 8-961-213-0278
"	" 8-917-347-1700
"	" 8(351) 269-44-75, 900-72-73
"	" 8(3512) 773-76-91

41.55-2005.

14 (4 .)

1			
2			
3			
4			
5			
6			
7			

ТСУ

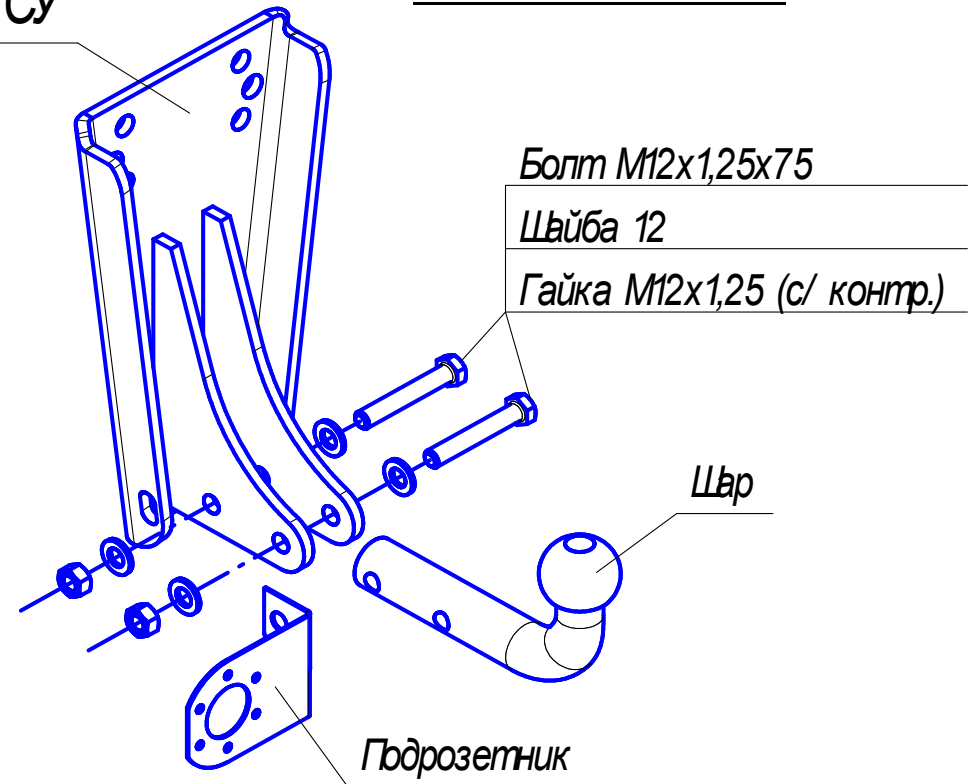

	1 .
	1 .
	1 .

	3 .
12 1,25 75	2 .
12 1,25 /	2 .
12	4 .
VH 0189	1 .
	1 .
130	1 .
	1 .

Схема обрезки кабеля

